

Warewashing

Single rinse rack type dishwasher, 200 racks/hour, electric - 50Hz (380-400V)

ITEM # _____

MODEL # _____

NAME # _____

SIS # _____

AIA # _____

520422 (ESR20EL5)

Single rinse Rack Type dishwasher, 200 racks/hour, electric, Left>Right, 380-400V/50Hz/3N (APAC & LA)

520423 (ESR20ER5)

Single rinse Rack Type dishwasher, 200 racks/hour, electric, Right>Left, 380-400V/50Hz/3N (APAC & LA)

Short Form Specification

Item No.

Unit to be Electrolux Professional single rinse rack type dishwasher. Operation direction from left to right or right to left. Single rinse with built-in stabilized pressure valve ensures the right rinsing pressure for optimum hygiene results. Powerful wash pump and specially designed wash spray arms guarantee cleaning. Washing is done with water circulating at 55-65°C. Final rinsing is done with clean water heated up to 80-90°C. Low rinse water consumption of 1.5 liter per rack at maximum speed of 200racks/hour. Double skin counter-balance door has heat and noise insulation with easy internal access.

Main Features

- Easy-to-use control panel.
- All internal components: wash and rinse arms, tank filters, curtains can be easily removed for cleaning.
- Maximum capacity per hour of 200 racks.
- Easy service from front and top.
- The feeding direction can be either left to right or right to left as it's reversible on site.

Construction

- Adjustable feet for full access underneath the machine for cleaning.
- All main components made in heavy duty anti-corrosive 304 type stainless steel: external front, side panels and internal chambers, wash and rinse arms, doors and rack transportation system.
- Dishwasher structure is held with stainless steel frame to provide long-term sturdiness.
- The unit is built on modularity concept for easy to add dryer module on-site.
- IPx4 water protection.
- Double skin insulated door reduces noise and heat loss.
- <p>The machine runs at DIN 10510 compliant speed.</p>
- <p>Reference norm used to measure the noise: IEC60335-2-58 annex AA.</p>

Sustainability



- Auto-start/stop equipped in different zones ensures that the zone runs only when a rack is passing through it. This reduces water, energy, chemical consumption and noise.
- Single rinse with stabilized pressure valve guarantees rinse water consumption of 1.5 liters/rack regardless of inlet water pressure to ensure low energy, water, detergent and rinse aid consumption.
- Built-in stabilized pressure valve ensures constant pressure throughout the rinsing cycle regardless of inlet water pressure.

Optional Accessories

- Medium hot air blower without door for single rinse Rack Type Dishwasher, electric, 570mm, 4.5kW, 380-400V/50 Hz/3N (APAC & LA) PNC 888000

APPROVAL: _____

Front

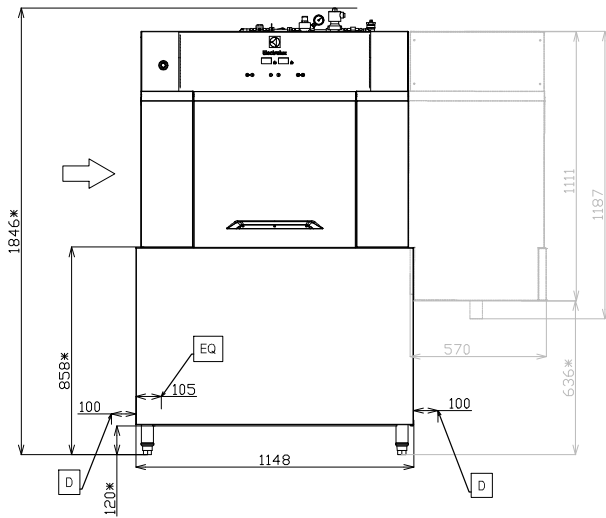

Front

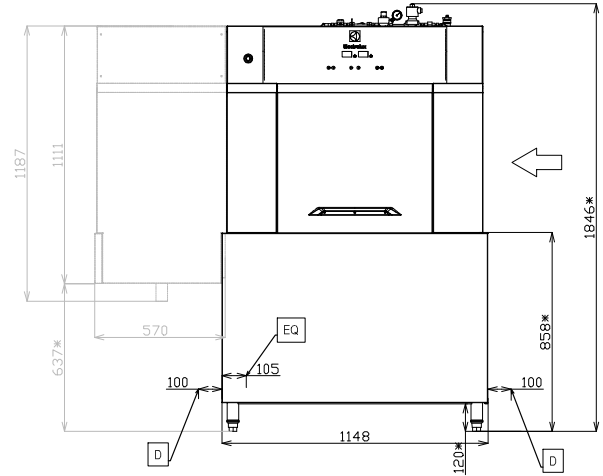

Side



Side

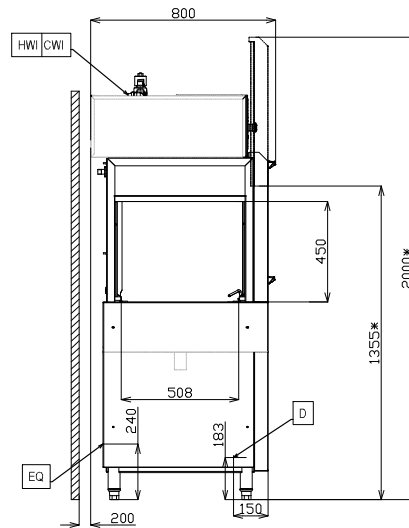

- CWI = Cold Water Inlet
- D = Drain
- EI = Electrical inlet (power)
- EO = Electrical Outlet
- EQ = Equipotential screw
- ES = Electrical signal IN/OUT
- HWI = Hot water inlet
- U = USB port

- CWI = Cold Water Inlet
- D = Drain
- EI = Electrical inlet (power)
- EO = Electrical Outlet
- EQ = Equipotential screw
- ES = Electrical signal IN/OUT
- HWI = Hot water inlet
- U = USB port

Top



Top

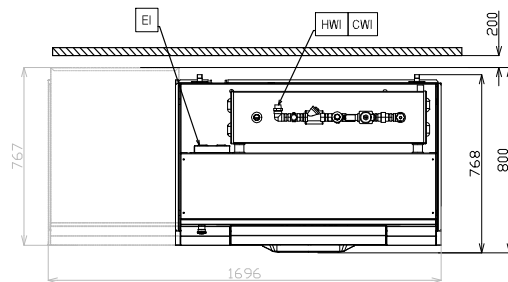

Electric

Supply voltage:	380-400 V/3N ph/50 Hz
Wash tank heating elements:	7.5 kW
2nd wash tank heating elements:	7.5 kW
Default Installed Power:	46 kW
Wash pump size:	1.9 kW
Boiler heating elements:	36 kW
Washing pump power (2nd wash):	1.9 kW

Water:

The higher the temperature, the faster the warm-up time.
 Recommended temperature of 50°C.

Tank capacity (2nd wash):	90 lt
Inlet hot water line size:	ISO 3/4" G
Drain line size:	2"
Inlet water supply pressure:	1-6 bar
Inlet water supply temperature (wash and rinse):	10 - 60°C
Inlet Water supply hardness:	14 (°fH) / 8 (°dH)
Flow rate of wash pump:	500 l/min
Wash tank size:	90 l
Rinse water consumption:	300 l/h

Key Information:

Height with door open:	2000 mm
Charging hole size (width):	508 mm
1st wash temperature:	55-65 °C
External dimensions, Width:	1148 mm
External dimensions, Depth:	800 mm
External dimensions, Height:	1846 mm
Charging hole size (height):	450 mm
Net weight:	258 kg
Shipping weight:	342.5 kg
Shipping height:	2060 mm
Shipping width:	870 mm
Shipping depth:	1500 mm
Shipping volume:	2.69 m ³
Washing tank (2nd wash):	55-65 °C
Productivity per hour (max speed):	200racks/3600dishes
Rinsing temperature:	80-90 °C

Air Emission:

Air humidity:	
520422 (ESR20EL5)	100%
520423 (ESR20ER5)	100%
Air flow:	
520422 (ESR20EL5)	170 m ³ /h
520423 (ESR20ER5)	170 m ³ /h
Air temperature:	45 °C

Sustainability

Rinse water consumption at max speed (l/rack):